

FIU COMBO DRAWER UNIT

- ALUMINUM CONSTRUCTION
- 1.5" CARGO RAIL AROUND PERIMETER
- RUBBER MATTING ON TOP
- 2" DIAMOND CUT BARRIER POWDER COATED BLACK

STORAGE DRAWER

- 11.5"H X 34.5"W X 24"D
- 200 LBS SLIDES
- 1X FRONT-TO-BACK DIVIDERS
- KEY LOCKING

RADIO DRAWER

- 6.5"H X 34.5"W X 24"D
- 200 LBS SLIDES
- KEY LOCKING
- PERFORATION AT FRONT, SIDES AND BACK
- FIXED DIVIDER
- REMOVABLE PAN 0.5"H

SIDE GUN BOX

- 20"H X 5.5"W X 40" D
- TRIGGER LATCH WITH KEY LOCKING
- 1X SHELF AT 7" HEIGHT

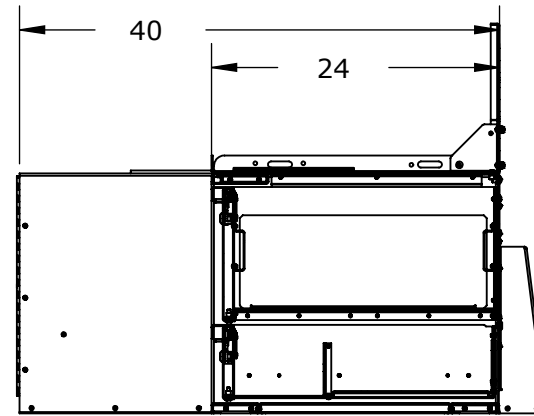
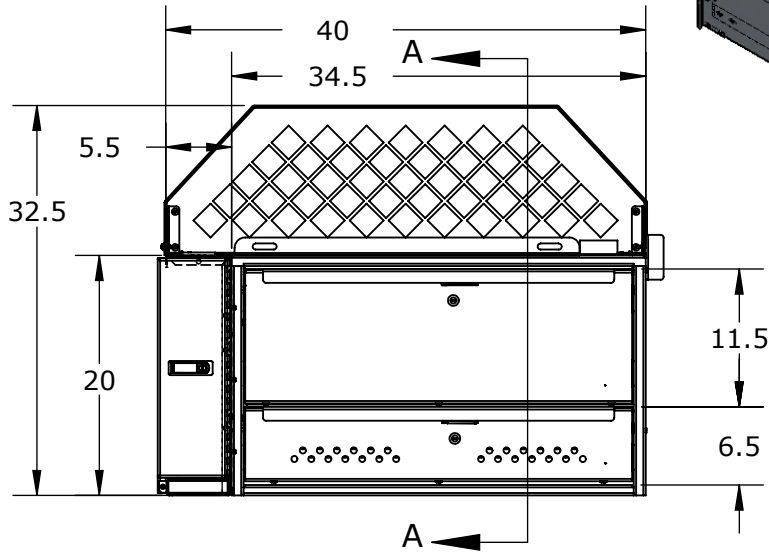
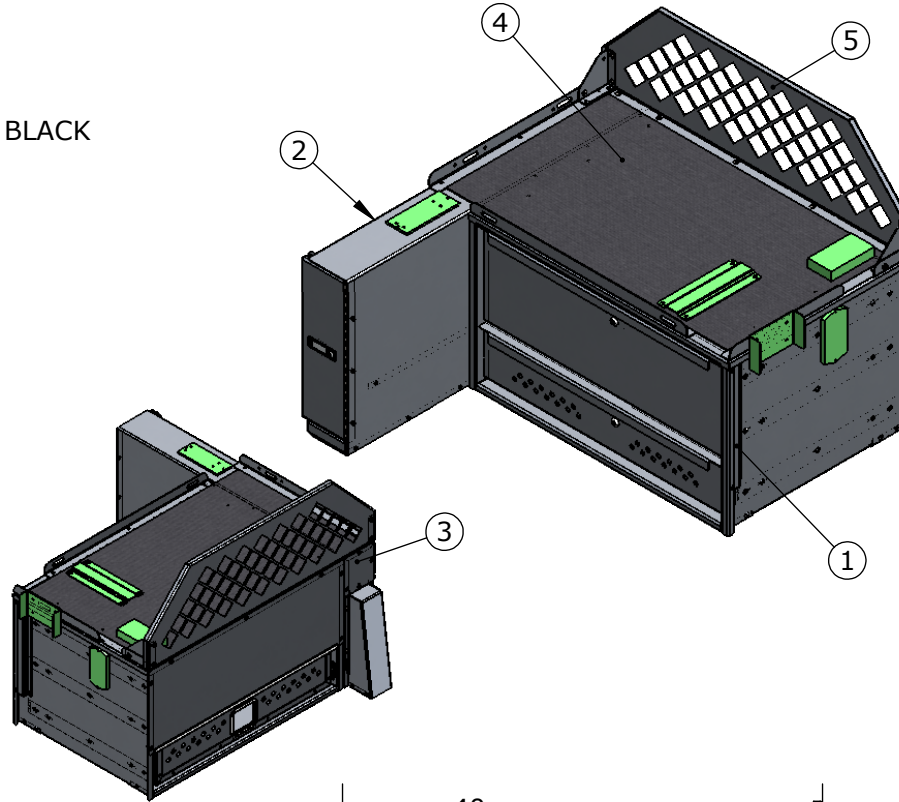

SECTION A-A

ITEM NO.	PART NUMBER	DESCRIPTION	QTY.	Revision
1	1216582	STACKED DRAWER SERIES	1	01
2	1217013	GUN BOX UNIT	1	01
3	1216591	CABINET BACK PANEL	1	01
4	RM^FIU-204040-TXDPS	RUBBER MAT	1	
5	1217595	BARRIER ASSEMBLY	1	01
6	RE^FIU-204040-TXDPS	RUBBER EDGE (60101013)	1	



Mobile Workspace Systems
 PH:(613)530.3419
 FAX:(613)546.5489

DESCRIPTION

COMBO DRAWER SERIES

PART NO.

FIU-204040-TXDPS

	NAME	DATE
DRAWN	JB	2018-08-20
CHECKED	DDR	Aug 21, 2018
RELEASED TO PRODUCTION		

PROPERTIES

MATERIAL: N/A
 THICKNESS: N/A
 FINISH*
 WEIGHT: 150.935 LB

TOLERANCES UNLESS OTHERWISE SPECIFIED:

X.X ± 0.025
 X.XX ± 0.010
 X.XXX ± 0.005

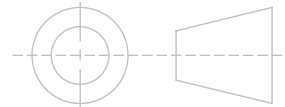

DO NOT SCALE DRAWING

PROPRIETARY AND CONFIDENTIAL

THE INFORMATION CONTAINED IN THIS DRAWING IS THE SOLE PROPERTY OF EZSTAK LLC. ANY REPRODUCTION IN PART OR AS A WHOLE WITHOUT THE WRITTEN PERMISSION OF EZSTAK LLC IS PROHIBITED.

SIZE **A** REV **01**

SCALE: 1:16 SHEET 1 OF 2

UNIT: IPS

Deburr All Edges