

NOTES:

- ALUMINUM CONSTRUCTION
- CABINET:**
- ANTI-SKID LINER ON TOP
- 1.5" CARGO RAIL AROUND SIDES AND FRONT
- MOUNTING TAHOE BRACKETS INCLUDED
- RADIO PAN ON REAR
- RUBBER MATTING ON TOP

TOP DRAWER:

- PUSH BUTTON SIMPLEX LOCK
- 2X 500LBS SLIDES
- RUBBER MATING (OPTIONAL)

BOTTOM MIDDLE DRAWER:

- STANDARD KEY LOCK
- 500LBS SLIDES
- RUBBER MATING (OPTIONAL)

SCALE STORAGE:

- OPEN SCALE STORAGE TO FIT 4 SCALES
- ALUMINUM DOORS W. LOCKING TRIGGER LATCHES

BARRIER ASSEMBLY FOR CTU 22"H X 47"W

- POWDERCOATED BLACK

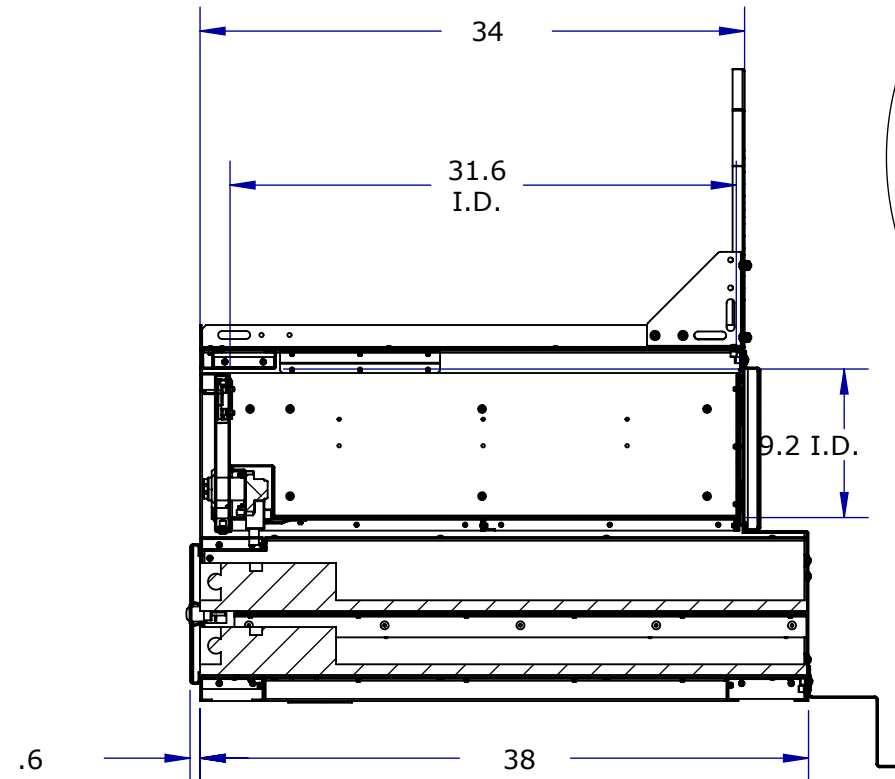
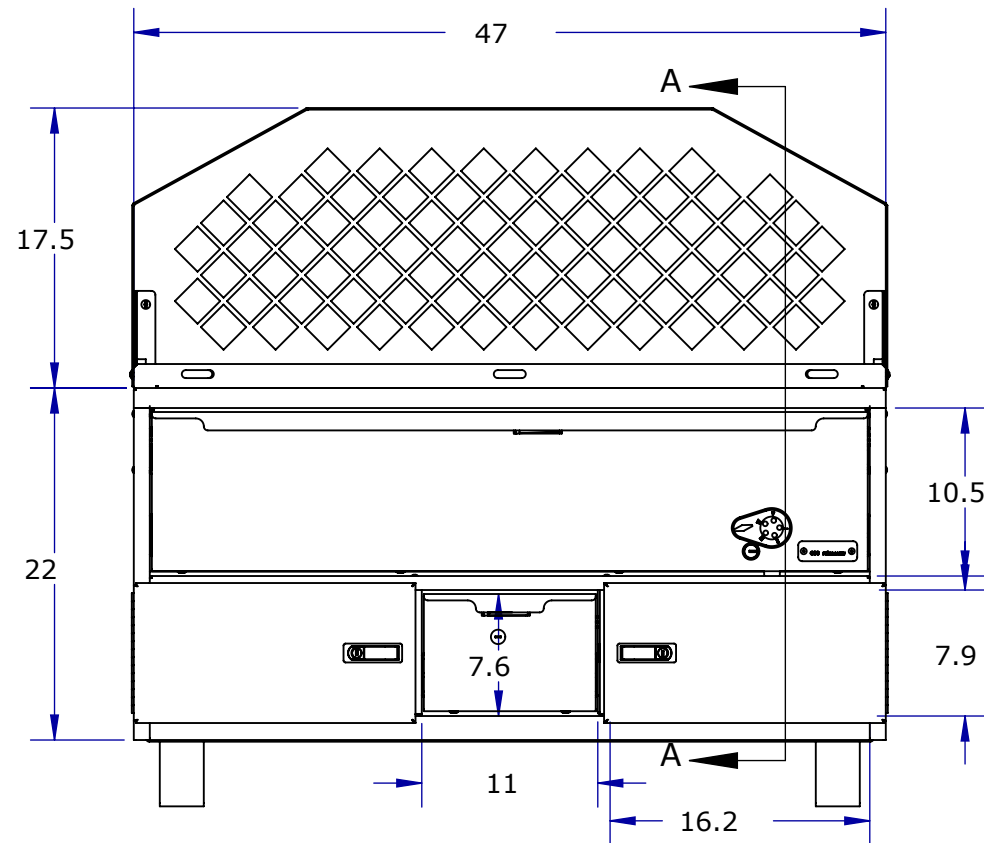
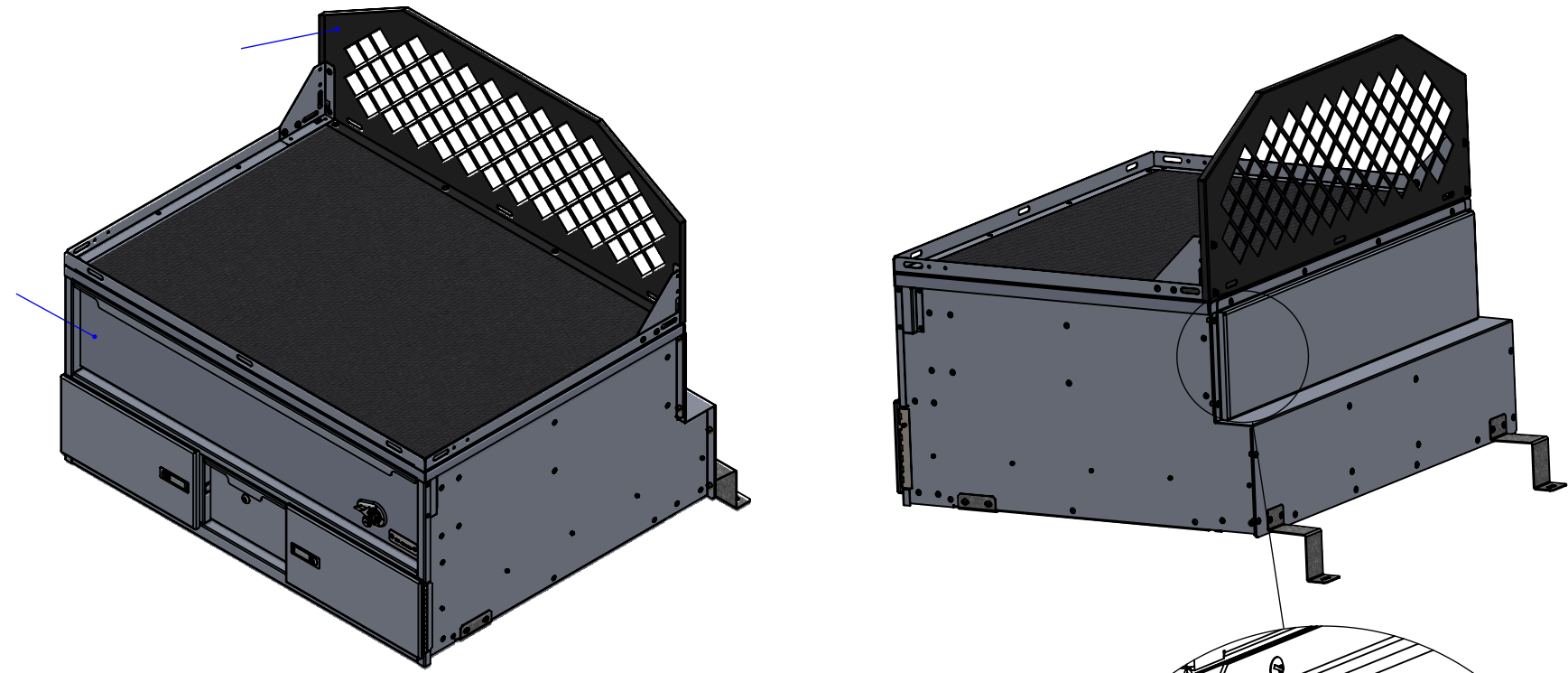

SECTION A-A
SCALE 1 : 12

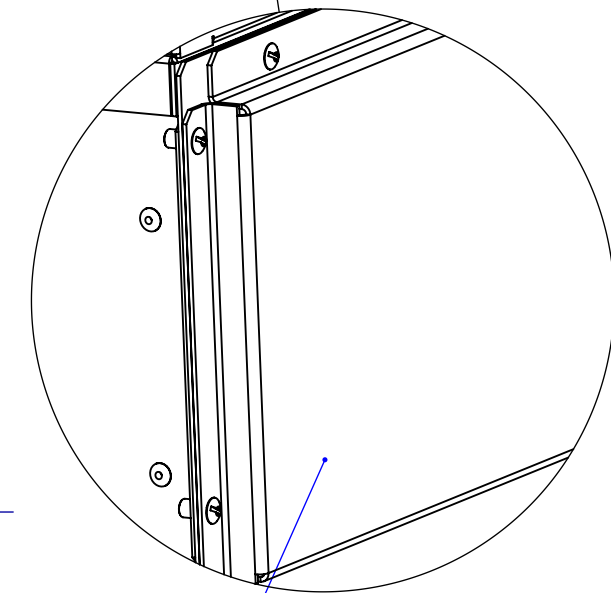

DETAIL B
SCALE 1 : 4

REMOVABLE REAR PANEL

| ITEM NO. | PART NUMBER | DESCRIPTION | QTY. |
|----------|-----------------|----------------------|------|
| 1 | CTU-224738-500 | CTU ORGANIZER SERIES | 1 |
| 2 | BR-17.54705-200 | BARRIER ASSEMBLY | 1 |

DISCLAIMER: By signing and dating this document, I agree that all specifications, notes and dimensions are clear, correct and in accordance with intended product use, content fit and function and product envelope fit and function. I understand this agreement to be binding and accept that any future change requests will be charged as additional work and managed through revision of this document. All custom orders cannot be cancelled and merchandise cannot be returned. If an order is cancelled by the purchaser after the order has been released to production, EZ STAK reserves the right to charge an order cancellation fee of 40% in addition to the normal restocking fee of 20%.

Signature: _____ Date: _____



PH:(613)530.3419
FAX:(613)546.5489

DESCRIPTION
**ORGANIZER SERIES -
SCALE UNIT**

PART NO.
6432-A00

| | NAME | DATE |
|-------------------------------|------|------------|
| DRAWN | vSi | 09/27/2019 |
| CHECKED | SB | 10/04/2019 |
| RELEASED TO PRODUCTION | | |

PROPERTIES

MATERIAL: N/A
FINISH: N/A
WEIGHT: 396.550 LB

TOLERANCES UNLESS OTHERWISE SPECIFIED:

- X.X ±0.025
- X.XX ±0.010
- X.XXX ±0.005
- X/X ±1/32
- X° ±1

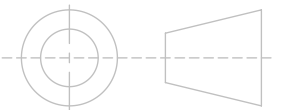

DO NOT SCALE DRAWING

PROPRIETARY AND CONFIDENTIAL

THE INFORMATION CONTAINED IN THIS DRAWING IS THE SOLE PROPERTY OF EZSTAK LLC. ANY REPRODUCTION IN PART OR AS A WHOLE WITHOUT THE WRITTEN PERMISSION OF EZSTAK LLC IS PROHIBITED.

SIZE REV
B -

SCALE: 1:16 SHEET 1 OF 1

UNIT: IPS

Deburr All Edges