

**DESCRIPTION
LAYOUT**

**PART NO.
5691-A00**

	NAME	DATE
DRAWN	RK	2/14/2019
CHECKED	-	-

NOT RELEASED

PROPERTIES

MATERIAL: N/A
THICKNESS: N/A
FINISH
WEIGHT: 329.467 LB

TOLERANCES UNLESS OTHERWISE SPECIFIED:

X.X ± 0.025
X.XX ± 0.010
X.XXX ± 0.005
X/X ± 1/32
X° ± 1°

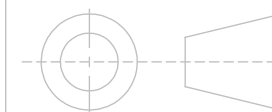

DO NOT SCALE DRAWING

PROPRIETARY AND CONFIDENTIAL

THE INFORMATION CONTAINED IN THIS DRAWING IS THE SOLE PROPERTY OF EZSTAK LLC. ANY REPRODUCTION IN PART OR AS A WHOLE WITHOUT THE WRITTEN PERMISSION OF EZSTAK LLC IS PROHIBITED.

SIZE **B** REV **C3**

SCALE: 1:50 SHEET 1 OF 4

UNIT: IPS

Deburr All Edges

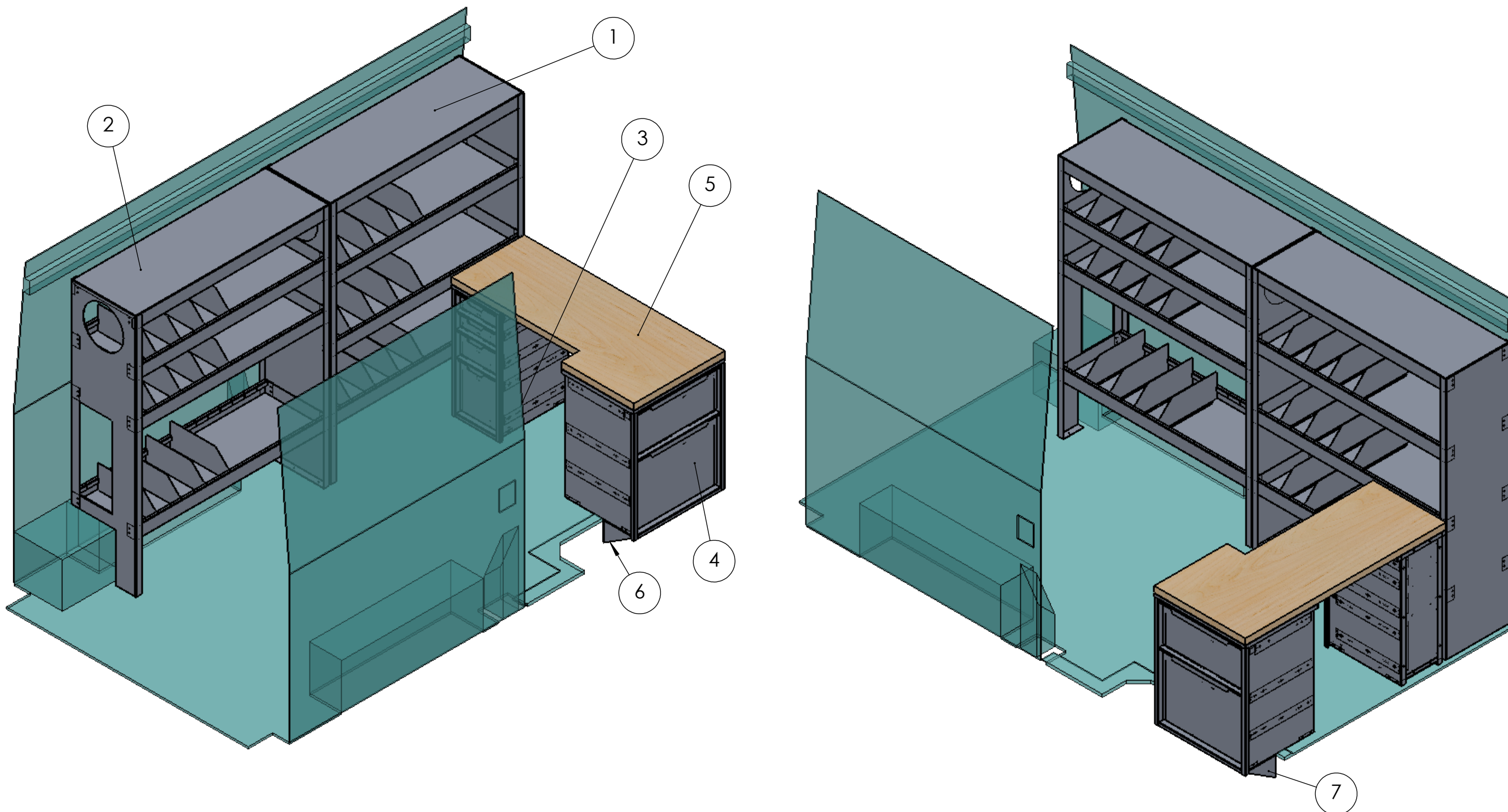

ITEM NO.	PART NUMBER	DESCRIPTION	QTY.
1	SU-604816-001	SHELF ASSEMBLY	1
2	5691-A02	SHELF ASSEMBLY	1
3	5691-A01	DRAWER UNIT ASSEMBLY	1
4	DU-2822.518-001	DRAWER UNIT ASSEMBLY	1
5	CT^5691-A00	BUTCHER BLOCK	1
6	1321442	SIDE BRACKET MOUNT LH	1
7	1321443	SIDE BRACKET MOUNT RH	1
8	1324689	TRANSIT 130W INSULATED WALL - 734-114-2313.MR	1
9	1324690	TRANSIT 130W INSULATED ROOF - 734-114-2613.MR	1

DISCLAIMER: By signing and dating this document, I agree that all specifications, notes and dimensions are clear, correct and in accordance with intended product use, content fit and function and product envelope fit and function. I understand this agreement to be binding and accept that any future change requests will be charged as additional work and managed through revision of this document. All custom orders cannot be cancelled and merchandise cannot be returned. If an order is cancelled by the purchaser after the order has been released to production, EZ STAK reserves the right to charge an order cancellation fee of 40% in addition to the normal restocking fee of 20%.

Signature: _____ Date: _____

NOTES:

- 4X DIVIDERS PER SHELF
 - CARGO NET AS SHOWN
 - 10" DIAMETER HOLE THROUGH SIDE
- PANELS OF ITEM (2) ONLY

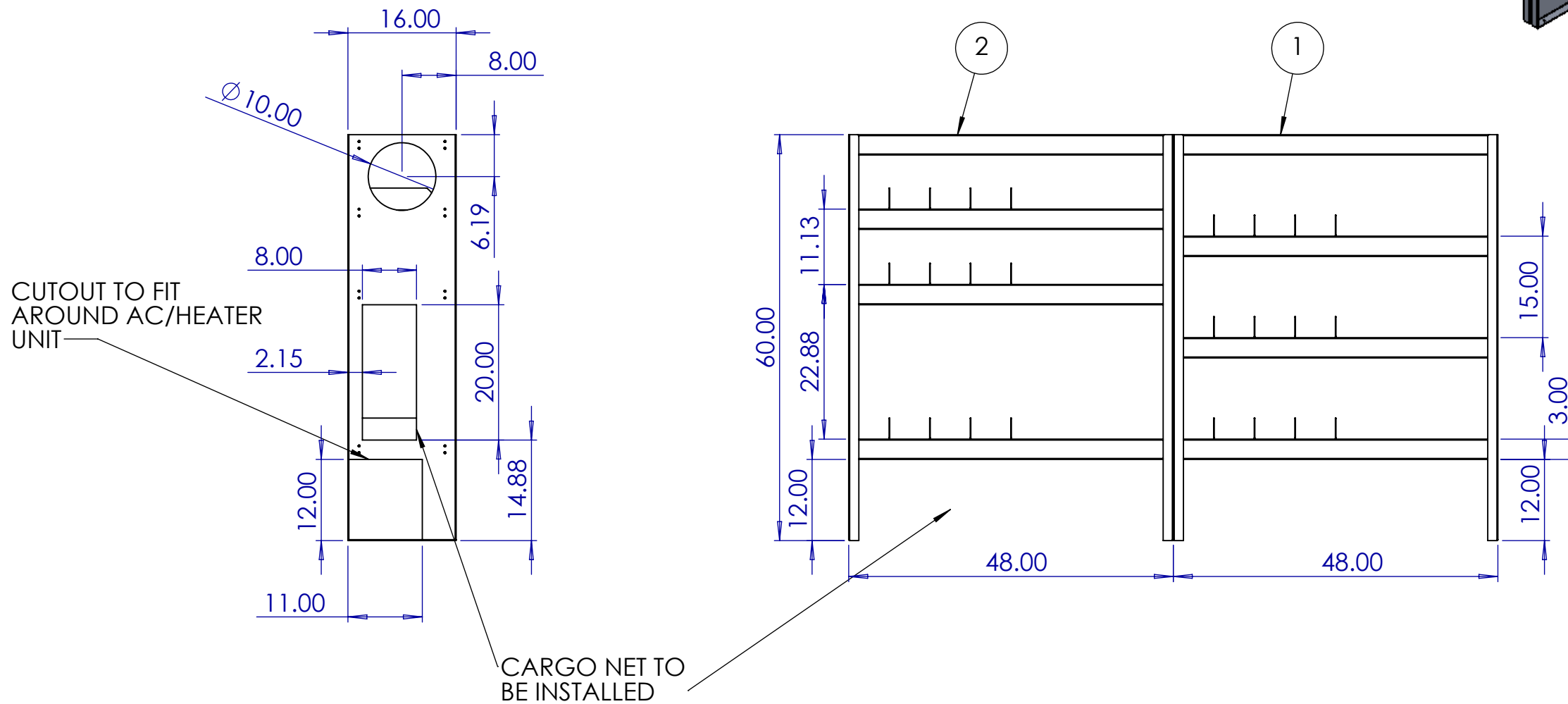
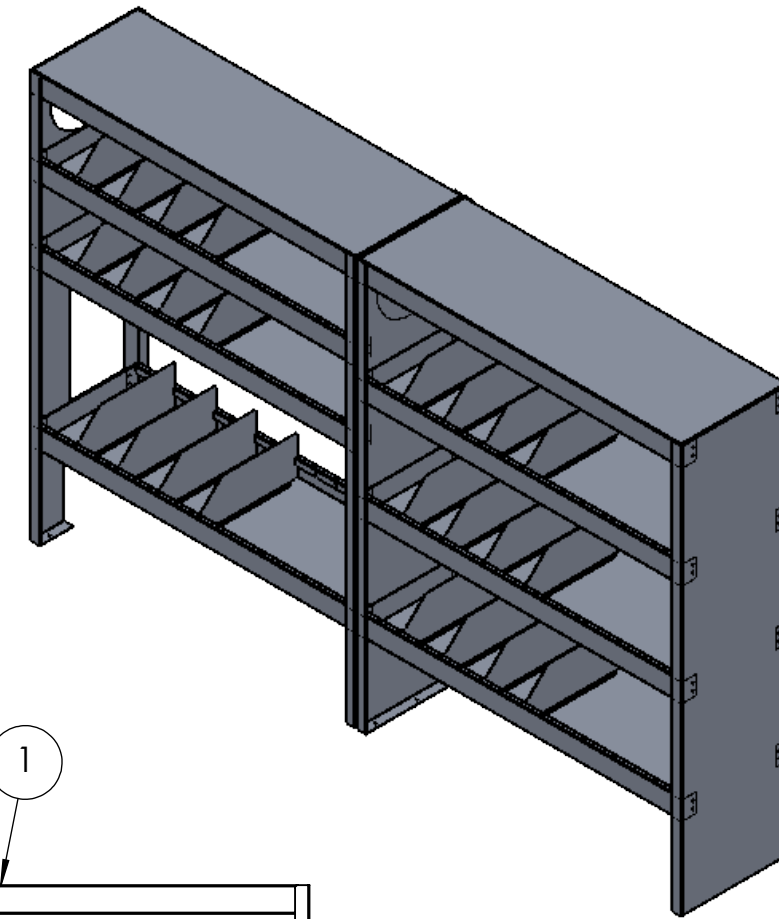

PH:(613)530.3419
FAX:(613)546.5489

DESCRIPTION
LAYOUT

PART NO.
5691-A00

	NAME	DATE
DRAWN	RK	2/14/2019
CHECKED	-	-

NOT RELEASED

PROPERTIES

MATERIAL: N/A
THICKNESS: N/A
FINISH
WEIGHT: 329.467 LB

TOLERANCES UNLESS OTHERWISE SPECIFIED:

X.X ± 0.025
X.XX ± 0.010
X.XXX ± 0.005
X/X ± 1/32
X° ± 1°

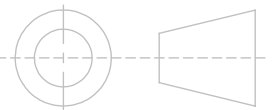

DO NOT SCALE DRAWING

PROPRIETARY AND CONFIDENTIAL

THE INFORMATION CONTAINED IN THIS DRAWING IS THE SOLE PROPERTY OF EZSTAK LLC. ANY REPRODUCTION IN PART OR AS A WHOLE WITHOUT THE WRITTEN PERMISSION OF EZSTAK LLC IS PROHIBITED.

SIZE **B** REV **C3**

SCALE: 1:50 SHEET 2 OF 4

UNIT: IPS

Deburr All Edges

DISCLAIMER: By signing and dating this document, I agree that all specifications, notes and dimensions are clear, correct and in accordance with intended product use, content fit and function and product envelope fit and function. I understand this agreement to be binding and accept that any future change requests will be charged as additional work and managed through revision of this document. All custom orders cannot be cancelled and merchandise cannot be returned. If an order is cancelled by the purchaser after the order has been released to production, EZ STAK reserves the right to charge an order cancellation fee of 40% in addition to the normal restocking fee of 20%.

Signature: _____ Date: _____

NOTES:

- 3 STANDARD DIVIDERS IN TOP TWO DRAWERS
- 4 LOCKIN-LOCKOUT SLIDES IN TOP DRAWER

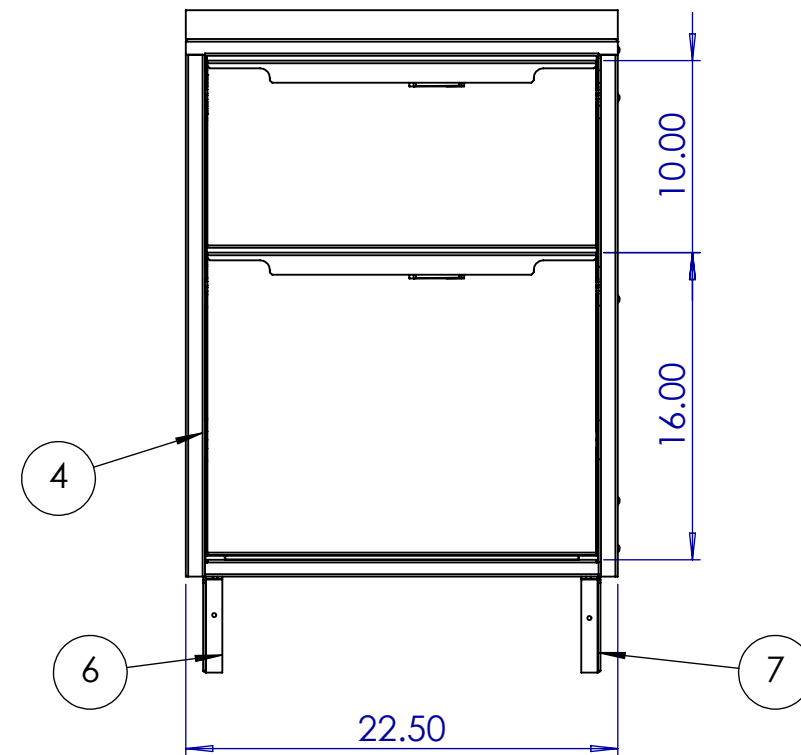
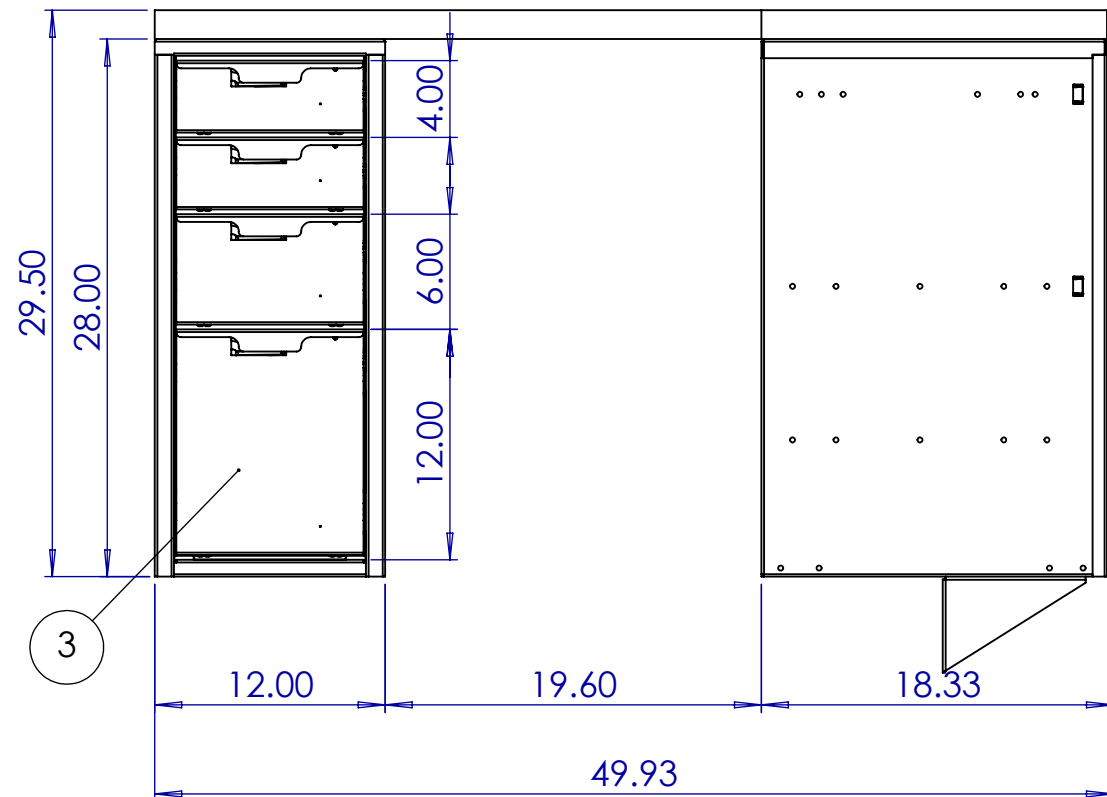
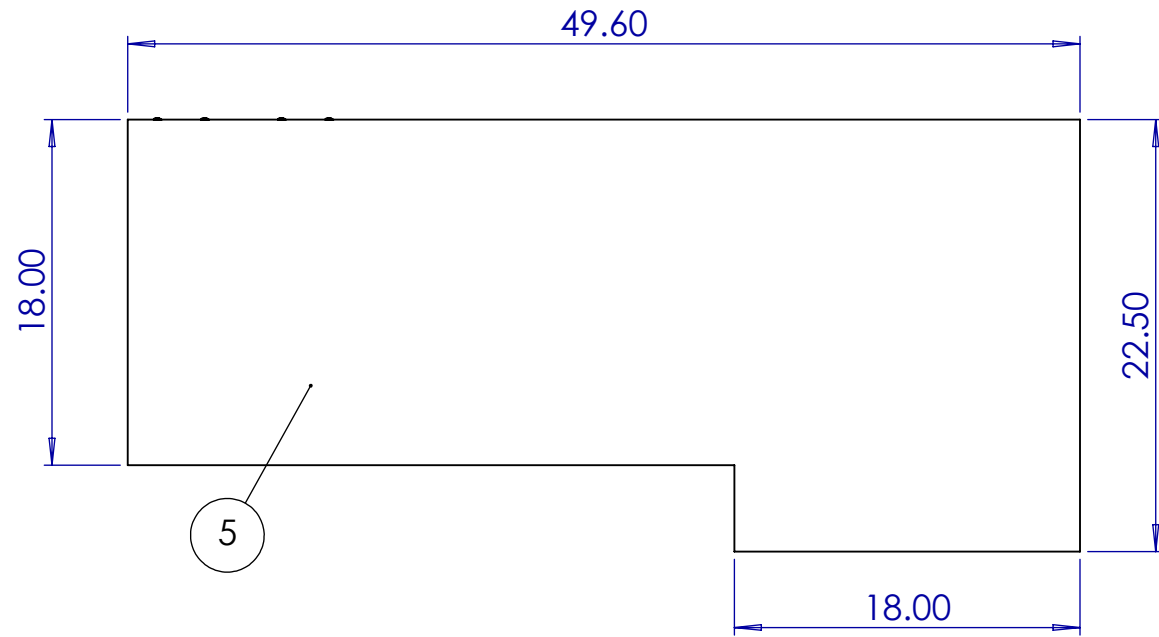

PH:(613)530.3419
FAX:(613)546.5489

DESCRIPTION
LAYOUT

PART NO.
5691-A00

	NAME	DATE
DRAWN	RK	2/14/2019
CHECKED	-	-

NOT RELEASED

PROPERTIES

MATERIAL: N/A
THICKNESS: N/A
FINISH
WEIGHT: 329.467 LB

TOLERANCES UNLESS OTHERWISE SPECIFIED:

X.X ± 0.025
X.XX ± 0.010
X.XXX ± 0.005
X/X ± 1/32
X° ± 1°

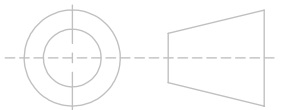

DO NOT SCALE DRAWING

PROPRIETARY AND CONFIDENTIAL

THE INFORMATION CONTAINED IN THIS DRAWING IS THE SOLE PROPERTY OF EZSTAK LLC. ANY REPRODUCTION IN PART OR AS A WHOLE WITHOUT THE WRITTEN PERMISSION OF EZSTAK LLC IS PROHIBITED.

SIZE **B** REV **C3**

SCALE: 1:50 SHEET 3 OF 4

UNIT: IPS

Deburr All Edges

DISCLAIMER: By signing and dating this document, I agree that all specifications, notes and dimensions are clear, correct and in accordance with intended product use, content fit and function and product envelope fit and function. I understand this agreement to be binding and accept that any future change requests will be charged as additional work and managed through revision of this document. All custom orders cannot be cancelled and merchandise cannot be returned. If an order is cancelled by the purchaser after the order has been released to production, EZ STAK reserves the right to charge an order cancellation fee of 40% in addition to the normal restocking fee of 20%.

Signature: _____ Date: _____

**DESCRIPTION
LAYOUT**

**PART NO.
5691-A00**

	NAME	DATE
DRAWN	RK	2/14/2019
CHECKED	-	-
NOT RELEASED		

PROPERTIES

MATERIAL: N/A
THICKNESS: N/A
FINISH
WEIGHT: 329.467 LB

TOLERANCES UNLESS OTHERWISE SPECIFIED:

X.X ± 0.025
X.XX ± 0.010
X.XXX ± 0.005
X/X ± 1/32
X° ± 1°

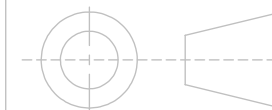

DO NOT SCALE DRAWING

PROPRIETARY AND CONFIDENTIAL

THE INFORMATION CONTAINED IN THIS DRAWING IS THE SOLE PROPERTY OF EZSTAK LLC. ANY REPRODUCTION IN PART OR AS A WHOLE WITHOUT THE WRITTEN PERMISSION OF EZSTAK LLC IS PROHIBITED.

SIZE **B** REV **C3**

SCALE: 1:20 SHEET 4 OF 4

UNIT: IPS

Deburr All Edges

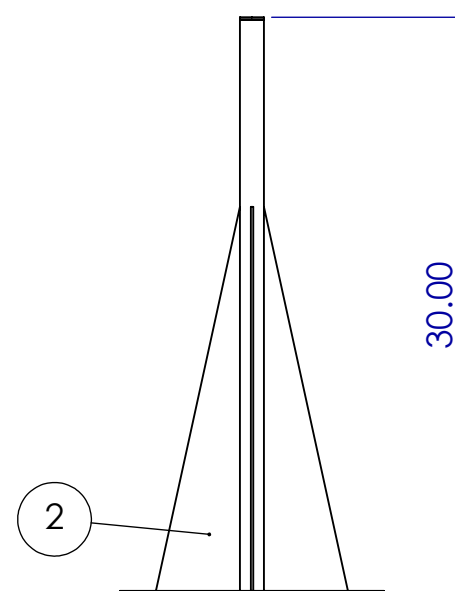
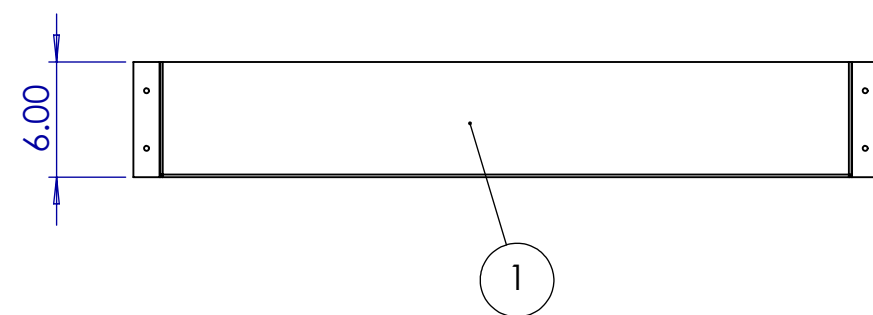
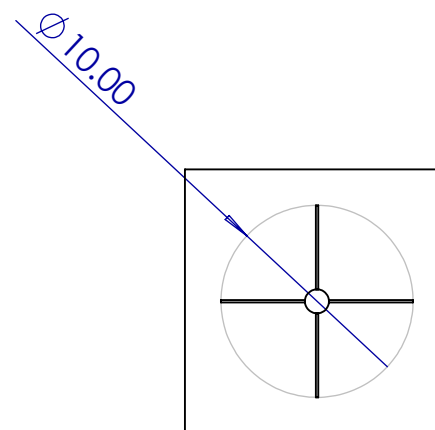
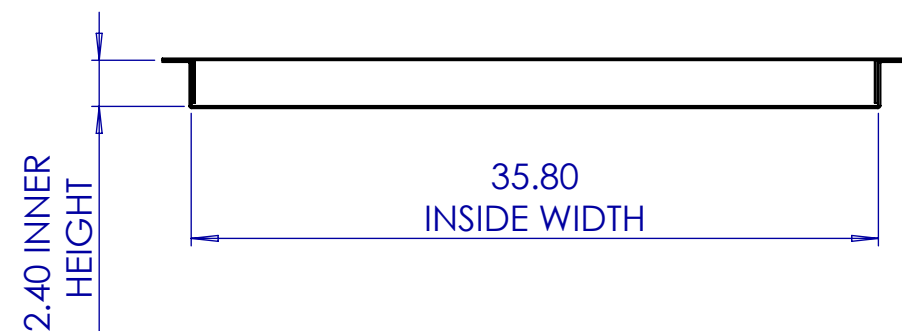
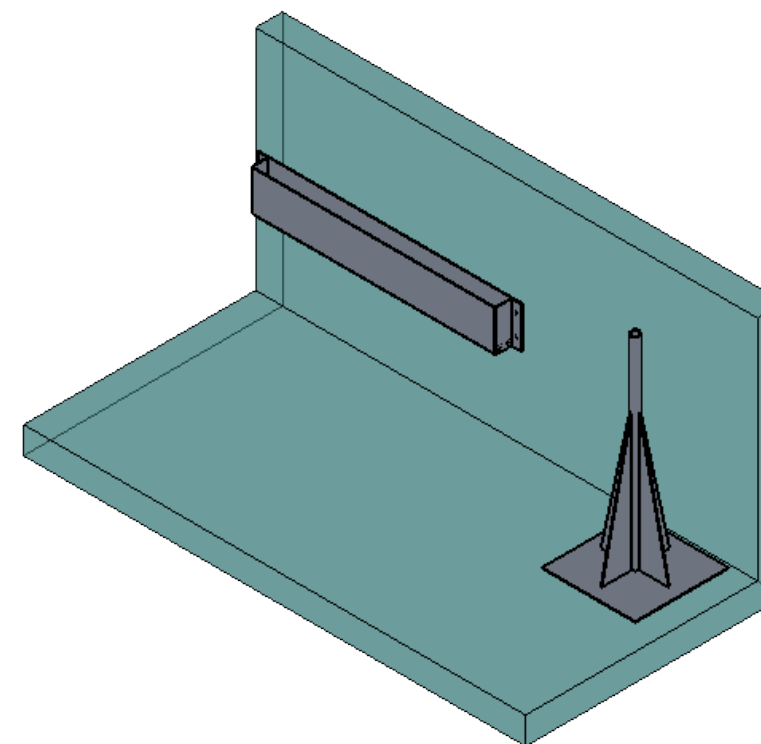

ITEM NO.	PART NUMBER	DESCRIPTION	QTY.
1	5691-A03	Sign board storage holder	1
2	5691-A04	CONE HOLDER	1

DISCLAIMER: By signing and dating this document, I agree that all specifications, notes and dimensions are clear, correct and in accordance with intended product use, content fit and function and product envelope fit and function. I understand this agreement to be binding and accept that any future change requests will be charged as additional work and managed through revision of this document. All custom orders cannot be cancelled and merchandise cannot be returned. If an order is cancelled by the purchaser after the order has been released to production, EZ STAK reserves the right to charge an order cancellation fee of 40% in addition to the normal restocking fee of 20%.

Signature: _____ Date: _____