

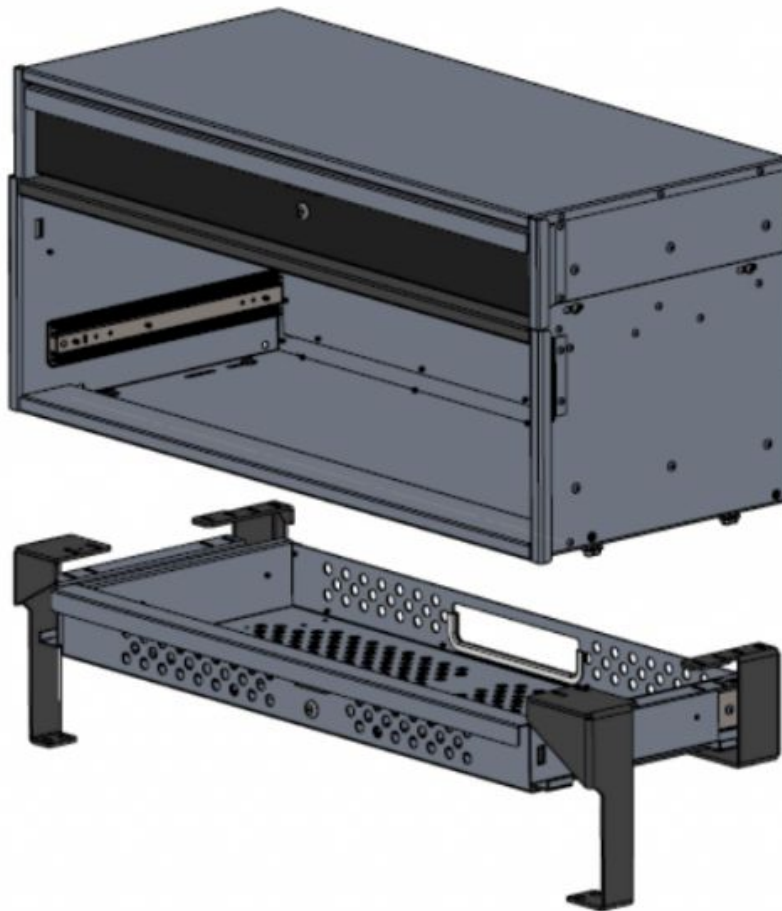

INSTALLATION INSTRUCTIONS

Ford Interceptor Radio Tray



1. AFTER THE BRACKETS ARE INSTALLED IN THE VEHICLE, THE RADIO TRAY AND THE PDU UNIT ARE FIXED TO THE BRACKETS TOGETHER.

2. THE RADIO TRAY AND THE PDU ARE INSTALLED UTILIZING THE SAME HOLES OF THE BRACKETS. HENCE, NO EXTRA HARDWARE IS REQUIRED TO FIX BOTH THE ENTITIES TO THE BRACKETS.

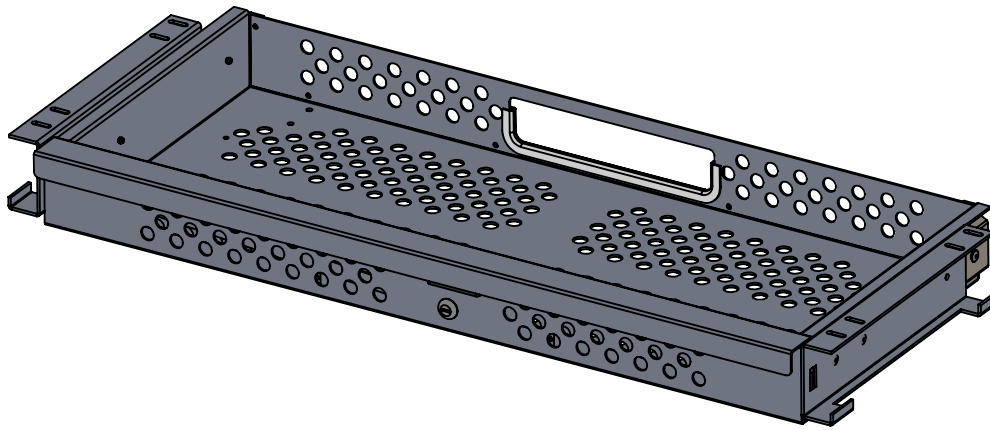

STEP 1:

REMOVE THE BOTTOM DRAWER OF PDU UNIT BY OPENING IT TO FULL EXTENSION AND PUSHING THE PLASTIC TABS IN OPPOSITE DIRECTIONS LOCATED ON BOTH SIDES OF THE SLIDE WHILE PULLING THE DRAWER STRAIGHT OUT.

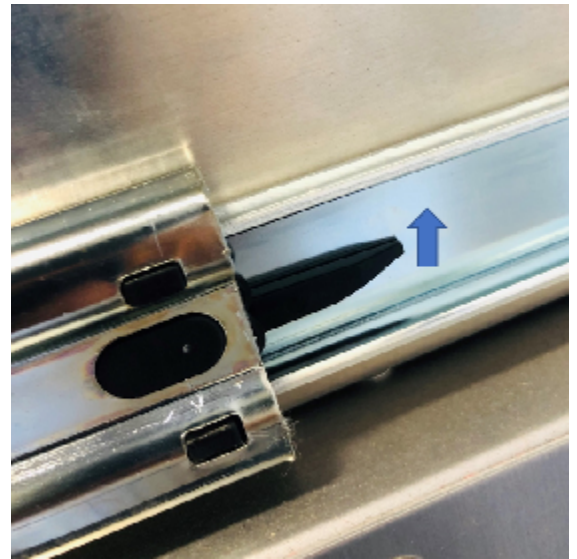
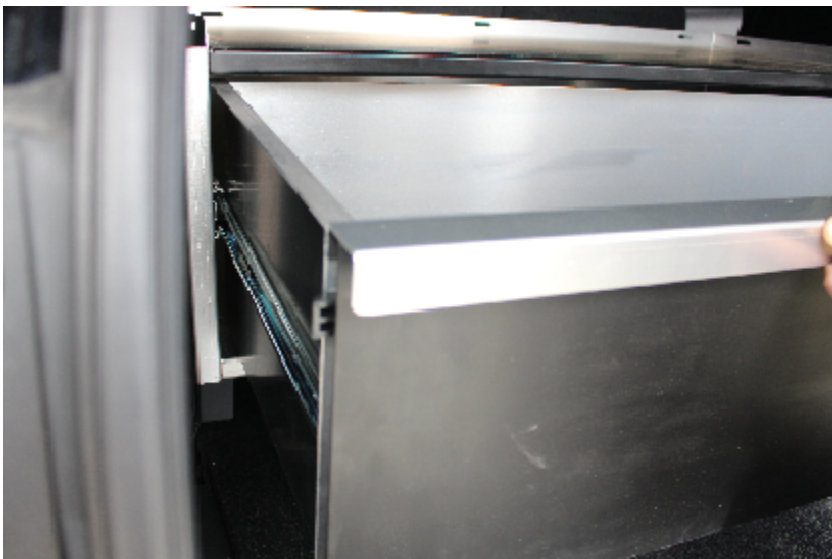

STEP 2:

PLACE THE PDU UNIT ABOVE THE BRACKETS AND HOLD THE RADIO TRAY BELOW THE BRACKETS. ALIGN THE SLOTS OF THE CABINET AND THE RADIO TRAY WITH THE SLOTS OF THE BRACKETS AND BOLT THEM TOGETHER USING THE SAME HARDWARE PROVIDED WITH THE PDU UNIT.

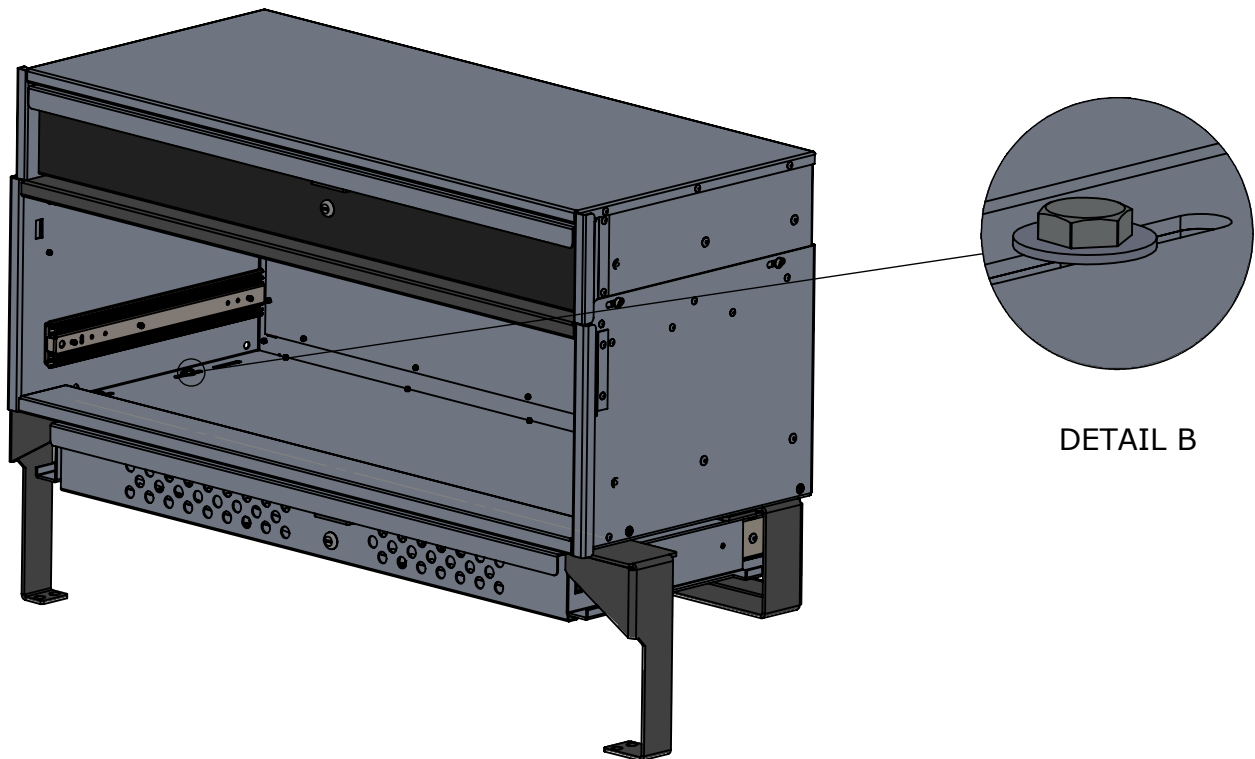
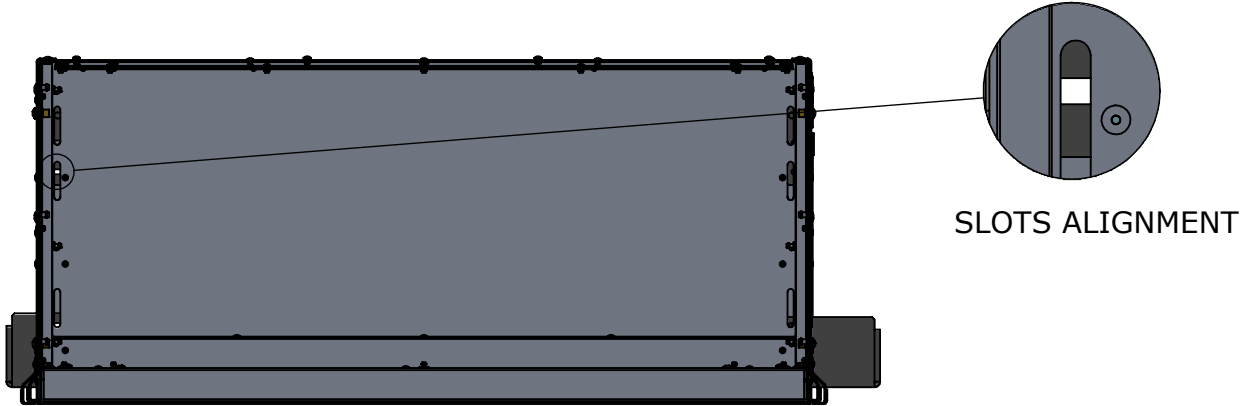

REVISION	DATE
I-1	07/12/2017

STEP 3:

PLACE THE DRAWER BACK INTO THE CABINET BY ALIGNING THE SLIDES ON EACH SIDE AND PUSHING THE DRAWER STRAIGHT IN UNTIL FULLY CLOSED.

THE INSTALLATION IS NOW COMPLETE.

